

## Description

E-T-A n|BoxBMM monitors battery cells performance status. The realtime status record and alarm provide effective solution to maintain battery performance over its lifetime.

n|Box BMM comes in 2 types. BMM cells to measure individual battery cells and BMM string to measure a group of battery cells.

The battery status, alarms, and reports can be viewed in web dashboard. The system can be set to send mobile notifications in the event of failure.

BMM : Battery Monitoring Module

## System

The Battery Monitoring System typically consists of:

- n|Box BMM Cell monitors voltage, temperature, liquid level, and impedance on each battery cells.
- n|Box BMM String monitors voltage and current in a group of battery cells.
- n|Box IoT Node communication gateway to web dashboard.

An n|Box IoT Node unit can manage up to 160 string and cell units.

## Applications

Data center and UPS, Base Transceiver Station (BTS), Building Automation, Telecom Infrastructure, Solar Powered Infrastructure.

## Features and Benefits

- Compact portable universal mount box
- Online monitoring with web dashboard
- Mobile notification to Android / iOS devices
- Wireless communication
- Data Logging
- SNMP, Modbus interface ready with n|Box IoT Node
- Technical support
- Customizable data visualization
- Customizable reports
- Local HMI display (custom request)

## Ordering information

### Type No.

IOT05A - X - C - 01	BMM Cell
IOT05A - X - S - 01	BMM String



## Technical data

### Hardware

Voltage Supply Rating	+9 V .. +24 V DC
Current Supply Rating	Sleep mode: 5mA Normal mode: 100mA
Voltage sensor	1 channel cell: 0 .. 3.3 V DC 8.5 .. 18 V DC string: 260.. 750V DC
Current sensor	1 channel (BMM String) 400 A
Temperature sensor	1 channel (BMM cell) NTC
Liquid sensor	1 channel (BMM cell) Non intrusive
LED	Power LED
Processor	32-bit
Memory	4 MB
Connectivity	WiFi 2.4 GHZ IEEE 802.11b/g/n
Digital Output	1 channel (dry contact)
Internal Resistance	20 mΩ

### Software

HTTP / HTTPS	Unit web access Server web access
Mobile Notification	Telegram Apps (Android / iOS)
SNMP	SNMP V2C / V3
Modbus	Modbus RTU over RS-485 Modbus TCP over Ethernet / WiFi

### General

Enclosure	Plastic
Flame rating	UL94V-0
Mount	Portable universal mount
Color	Black
Dimension (mm)	63.5 x 63.5 x 22.9
Mass	Appr. 180 g
Operating temperature	-10...+50 °C
Storage temperature	-30...+70 °C

Dimension and Type

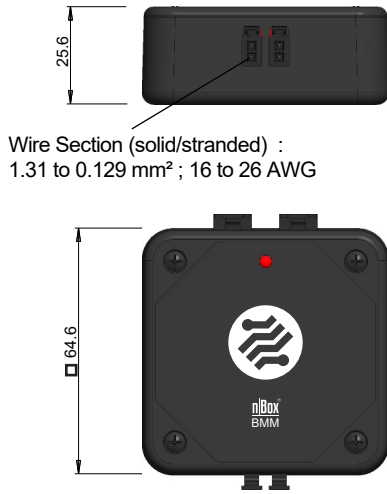

Device Type



IOT05A-X-S  
string

IOT05A-X-C  
cell

This is a metric design and millimeter dimensions (mm)  
The dimension is not binding and there might be further updates

Application Example

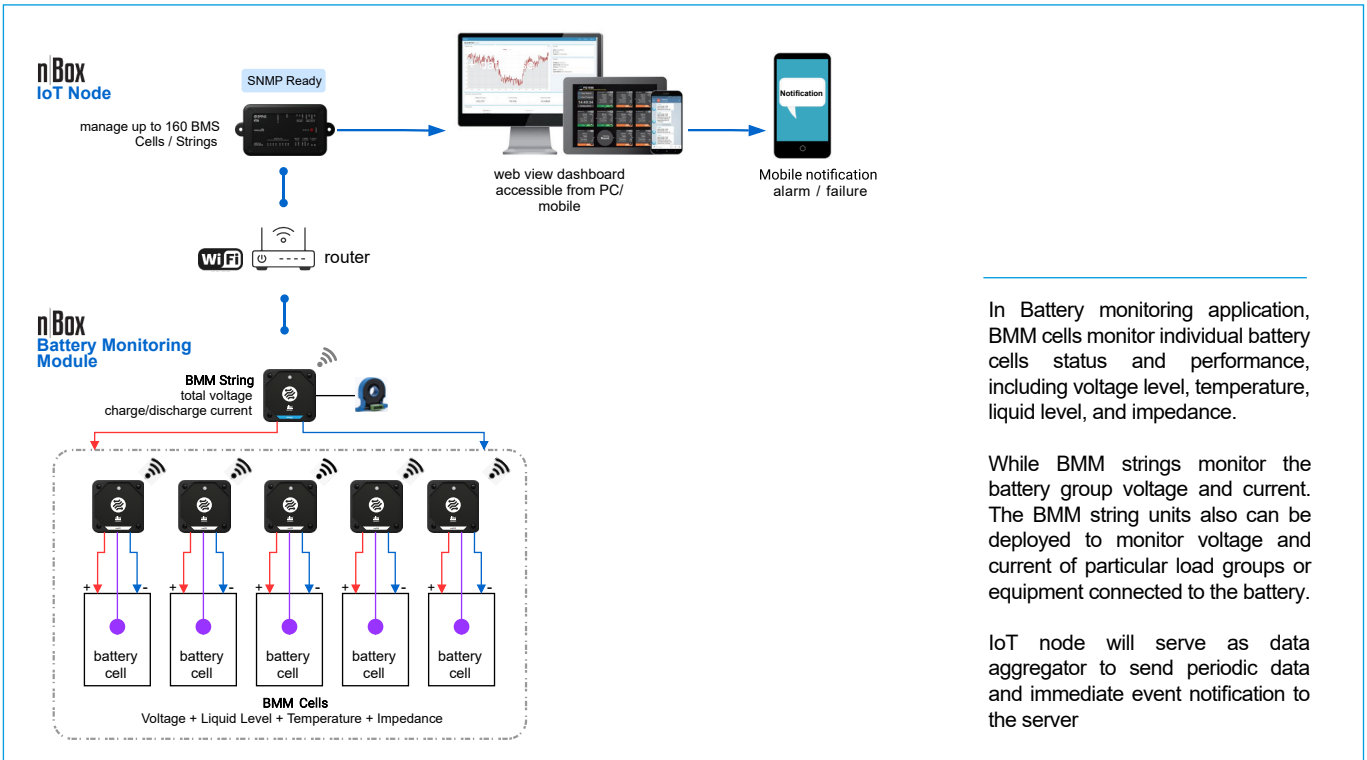

In Battery monitoring application, BMM cells monitor individual battery cells status and performance, including voltage level, temperature, liquid level, and impedance.

While BMM strings monitor the battery group voltage and current. The BMM string units also can be deployed to monitor voltage and current of particular load groups or equipment connected to the battery.

IoT node will serve as data aggregator to send periodic data and immediate event notification to the server



PT. E-T-A Indonesia  
Jl. Berbek Industri III / 5 Sidoarjo 61256  
Jawa Timur, Indonesia  
Phone: +62 31 849 6226. Fax : +62 31 849 6225  
E-Mail : customer.service@e-t-a.co.id  
[www.e-t-a.co.id](http://www.e-t-a.co.id)

Technical changes, misprints and errors reserved.